

Installation Guidelines

QuietBoard on Metal Partition System

Before Installation

Ensure that the metal partitioning system is installed fully in accordance with the manufacturer's instructions.

Storage

QuietBoard must be kept in a dry storage area. It must be stored horizontally.

Installation

QuietBoard may be fitted with either side out, depending on the surface finish that is to be used; see the section below entitled Surface Finishing.

QuietBoard is fitted in a staggered pattern (see Figure 1) and is screwed directly to both sides of the studwork using 25mm countersunk screws at approximately 300mm centres. Apply a bead of suitable adhesive to all edges and ensure that the rebated edges overlap fully. Where possible, ensure that joints occur over studwork members.

Where **QuietBoard** meets ceilings, floors, door and window openings and adjoining walls, the rebate should be trimmed off to ensure that the panels butt up at their full thickness (see Figure 2). CMS Acoustics dB Acoustic Sealant should be applied in all these cases.

To ensure acoustic integrity, butt joints should not be used anywhere else.

25mm mineral fibre must be hung in the cavity.

Electrical Fittings

For the optimum acoustic performance any sockets or switches should be either treated with CMS Acoustic Protection Boxes. Alternatively they can be surface mounted with wires fed through a small hole in the **QuietBoard**, which are subsequently sealed with a suitable filler.

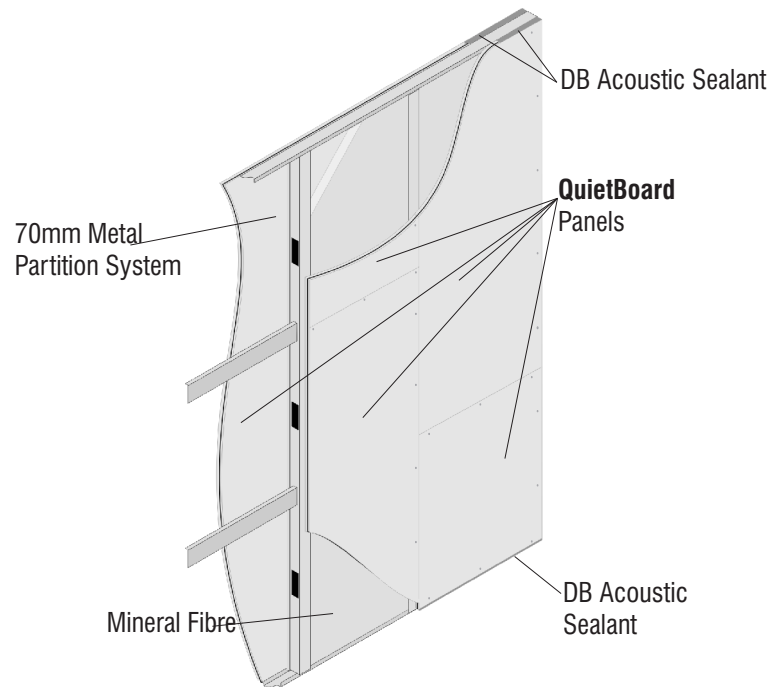

Figure 1

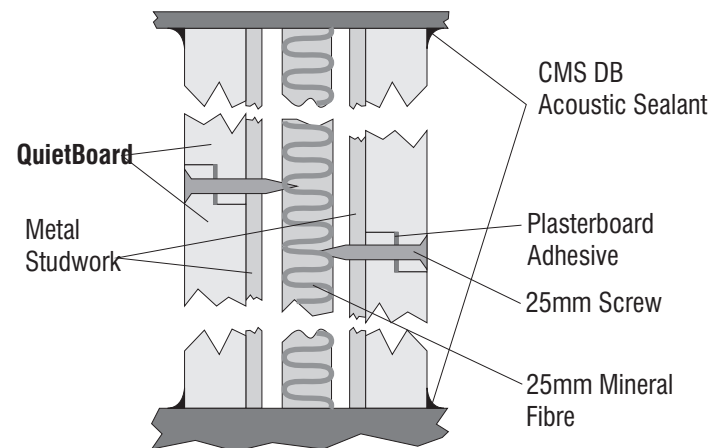

Figure 2

Surface Finishing

QuietBoard must be skimmed with plaster or covered with an additional layer of plasterboard prior to decorating.

When a plaster skim is to be used we recommend that the off-white side is installed to the outside.

HEALTH AND SAFETY

Handling

QuietBoard can be awkward to lift. Please observe proper lifting methods when transporting it around site, by hand.

Cutting

The cutting of **QuietBoard**, either by hand or machine, will produce dust which may be an irritant if inhaled. Always use dust masks when carrying out any cutting operations.

E-mail: info@cmsacoustics.co.uk

Web: www.cmsacoustics.co.uk

Northern Office: 11a, Eagle Park, Eagle Park Drive, Warrington WA2 8JA

Tel: 01925 577711 Fax: 01925 577733

Southern Office: 2 Luard Way, Birch, Colchester, Essex CO2 0LR

Tel: 01206 330810 Fax: 01206 330830

IMPORTANT: Directions for use are given for guidance only and are not intended to form part of any contract. They should be varied or adapted to suit your particular materials or conditions of use. Goods supplied by the company are made to approved standards from the highest quality raw materials but no warranty or guarantee is given as to their suitability for any particular purpose or application, and no liability is accepted for any loss or damage arising directly or indirectly from the use of the Company's products irrespective of any information given to us as to intended use of such products. It is therefore recommended that prospective users should test a sample of this product under their own conditions to satisfy themselves that the product is suitable for the purpose intended.

CAIG 0004 - 1 1005 © CMS Acoustic Solutions Ltd 2005